

19

GROUNDING CLAMP GRAPA DE TIERRA

Use:

For connection of grounding rod or IPS tube and copper or aluminum cables (when tin plated).

Utilización:

Para conexión de varilla de tierra o tubo IPS para alambres y cables de cobre o aluminio (si fuese bañado con estaño).

Conductors:

Copper and aluminum wires and cables, metric series and AWG.

Conductores:

Alambres e cables de cobre o aluminio, serie métrica y AWG.

Composite on:

Manufactured with high mechanical resistance copper, with electrolytic galvanized steel screws.

Composición:

Fabricado en aleación de cobre de alta resistencia mecánica, con tornillo de acero de zinc electrofórico.

Finish:

Frost sand blasted or electrolytic tin plated.

Acabamiento:

Salpicado opaco o bañado con estaño electrofórico.

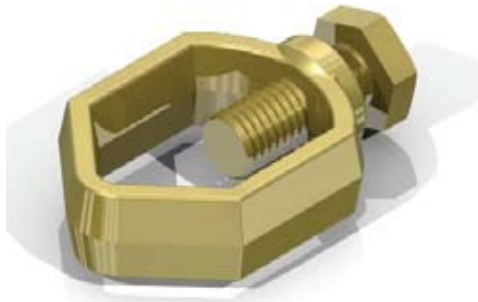

Fig.01



Fig.02

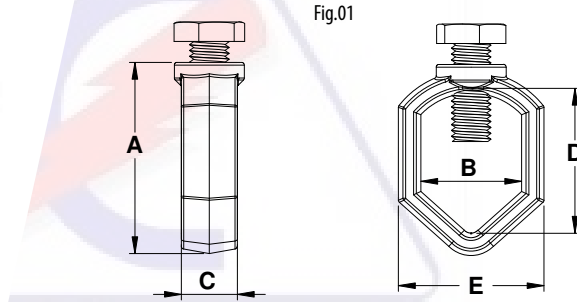

Fig.01

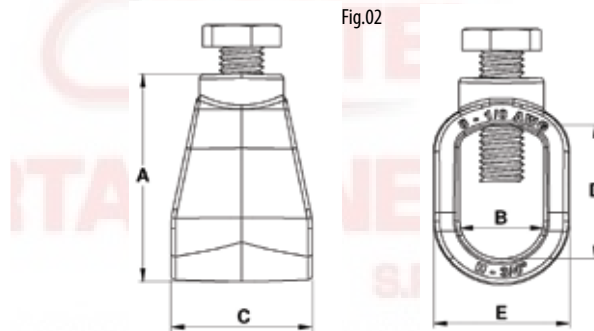

Fig.02

CODE / CÓDIGO	FIGURE / FIGURA	GROUNDING / TOMA DE TIERRA				CONDUCTORS / CONDUCTORES		DIMENSIONS (mm) / DIMENSIONES (mm)					HEXAGONAL SCREW / TORNILLO HEXAGONAL		
		ROD / VARILLA		IPS TUBES / TUBOS IPS		mm ²	AWG	A	B	C	D	E	MAT.	THREAD / ROSCA	COMP.
		POL. / PULG.	POL. / PULG.	POL. / PULG.	Ø mm										
TTC001-1	1	1/2-5/8	1/4	13,70	6-35	10-2	34,60	15,80	12,00	22,00	26,20	STEEL / ACERO	5/16"	3/4"	
TTC002-1	1	1/2-5/8	1/4	13,70	6-35	10-2	30,20	15,90	9,20	21,00	22,00	STEEL / ACERO	1/4"	3/4"	
TTC003-1	1	5/8-3/4	3/8	17,20	6-70	10-2/0	41,00	18,80	13,70	27,00	28,80	STEEL / ACERO	5/8"	3/4"	
TTC004-1	2	5/8	1/4	13,70	10-50	8-1/0	43,50	16,50	31,70	26,80	28,20	STEEL / ACERO	3/8"	1"	
TTC007-1	1	1/2-5/8	1/4	13,70	10-50	8-1/0	36,00	16,00	21,00	25,00	22,00	STEEL / ACERO	3/8"	7/8"	
TTC008-1	1	3/8-1/2	-	-	6-35	10-2	27,50	11,00	21,30	15,00	19,00	STEEL / ACERO	5/16"	5/8"	
TTC009-1	2	5/8-3/4	3/8	17,20	10-50	8-1/0	46,70	18,00	31,70	30,00	30,50	STEEL / ACERO	M 10	25,0	
TTC010-1	2	1/2-5/8	1/4	13,70	6-35	10-2	35,00	15,00	26,00	22,00	26,00	STEEL / ACERO	M 10	20,0	
TTC011-1	1	1/2-5/8	1/4	13,70	6-35	10-2	35,60	15,30	9,70	20,80	24,00	STEEL / ACERO	5/16"	5/8"	

NOTE: for bronze clamp, add 200 to the code number (ex: TTC007-1 bronze = TTC207-1)
for tin plated clamp, replace letter C in the code with S (ex: TTC007-1 tin plated = TTS007-1)
for hot-dip galvanized steel screw, replace -1 with -2 in the product code (ex: TTC007-1 with hot-dip galvanized steel screw - TTC007-2)
for bronze screw, replace -1 with -6 in the product code (ex: TTC007-1 with bronze screw = TTC007-6)
for brass screw, replace -1 with 8 in the product code (ex: TTC007-1 with brass screw = TTC007-8)

OBS.: para la grapa en bronce, sumar 200 al número del código (ej.: TTC007-1 en bronce = TTC207-1)
para la grapa bañado con estaño, cambiar la letra C del código por S (ej.: TTC007-1 bañado con estaño = TTS007-1)
para el tornillo en acero galvanizado en caliente, cambiar -1 por -2 en el código del producto (ej.: TTC007-1 con tornillo en acero galvanizado en caliente = TTC007-2)
para el tornillo en bronce, cambiar -1 por -6 en el código del producto (ej.: TTC007-1 con tornillo de bronce = TTC007-6)
para el tornillo en latón, cambiar -1 por -8 en el código del producto (ej.: TTC007-1 con tornillo de latón = TTC007-8)



CIMATEL
IMPORTACIONES
S.R.L.

DISTRIBUIDORES DE MATERIALES ELÉCTRICOS
DE ALTA, MEDIA Y BAJA TENSIÓN